

## IRUNA 12V Universal Vacuum Pump

All power assisted brakes are dependant on vacuum which is usually derived from the engine on petrol engines and should the engine stall and cut out you will only have the use of any vacuum left in the power brake booster. On a diesel engine, (as is used on most 4x4) an alternator driven pump is usually used and the same situation will apply. This is shown in more detail on our technical training pages on our website. More brake applications are used on off road and mountainous driving and the loss of vacuum is faster than normal. By fitting the IRUNA Vacuum pump and reserve tank assembly you will always be sure of having vacuum when needed. For peace of mind this is a MUST if towing a trailer or caravan.

The 5202000 IRUNA 12V Universal Vacuum Pump fits every make of vehicle with Petrol or Diesel engines. It can be used as a replacement for all gear or Alternator driven pumps or as a twin. Adapts to all vehicles on a stand-alone basis and can be mounted on any solid part of the vehicle. With the automatic self switch on/off relay when vacuum is low, you have reduced the risk of loss of vacuum to your booster as you will never "run out of vacuum" even on idle or offroad trail driving on the "Koppies" or mountains.

Together with the T659 specially designed vacuum reserve tank you will even have, vacuum assist should your engine stall. As long as you have the 12v connection, you will have peace of mind.

Complete kit Consists of:

- Electrical vacuum compressor pump # 5202000
- Relay with cut out switch
- Electronic vacuum distributor with cutout controller
- Other accessories (screws, nuts, washers, wiring and fittings)

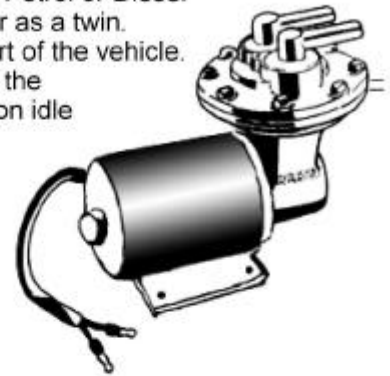

25 City & Suburban Rd, JHB

Tel: 011-334-7030

Fax: 011-334-5993

Email: [wingate@iafrica.com](mailto:wingate@iafrica.com)

Web: [www.winbrake.com](http://www.winbrake.com)



For more information please complete the enquiry form on the website or call:

Raven: ext 202 Dean: ext 229  
Fred: ext 214 Billy: ext 206

## IRUNA 12V Universal Vacuum Pump

All power assisted brakes are dependant on vacuum which is usually derived from the engine on petrol engines and should the engine stall and cut out you will only have the use of any vacuum left in the power brake booster. On a diesel engine, (as is used on most 4x4) an alternator driven pump is usually used and the same situation will apply. This is shown in more detail on our technical training pages on our website. More brake applications are used on off road and mountainous driving and the loss of vacuum is faster than normal. By fitting the IRUNA Vacuum pump and reserve tank assembly you will always be sure of having vacuum when needed. For peace of mind this is a MUST if towing a trailer or caravan.

The 5202000 IRUNA 12V Universal Vacuum Pump fits every make of vehicle with Petrol or Diesel engines. It can be used as a replacement for all gear or Alternator driven pumps or as a twin. Adapts to all vehicles on a stand-alone basis and can be mounted on any solid part of the vehicle. With the automatic self switch on/off relay when vacuum is low, you have reduced the risk of loss of vacuum to your booster as you will never "run out of vacuum" even on idle or offroad trail driving on the "Koppies" or mountains.

Together with the T659 specially designed vacuum reserve tank you will even have, vacuum assist should your engine stall. As long as you have the 12v connection, you will have peace of mind.

Complete kit Consists of:

- Electrical vacuum compressor pump # 5202000
- Relay with cut out switch
- Electronic vacuum distributor with cutout controller
- Other accessories (screws, nuts, washers, wiring and fittings)

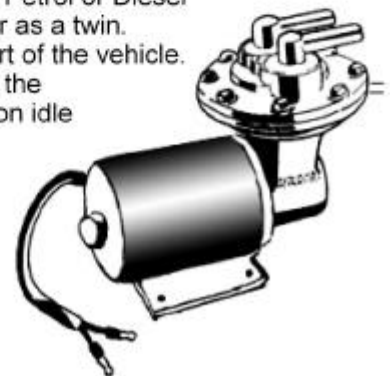

25 City & Suburban Rd, JHB

Tel: 011-334-7030

Fax: 011-334-5993

Email: [wingate@iafrica.com](mailto:wingate@iafrica.com)

Web: [www.winbrake.com](http://www.winbrake.com)



For more information please complete the enquiry form on the website or call:

Raven: ext 202 Dean: ext 229  
Fred: ext 214 Billy: ext 206